

AD 694639

DIGITAL COMPUTER NEWSLETTER

OFFICE OF NAVAL RESEARCH · MATHEMATICAL SCIENCES DIVISION

Vol. 16, No. 1
(Includes Vol. 14
No. 4 and Vol. 15
Nos. 1-4)

Gordon D. Goldstein, Editor

January 1964
(Period of October
1962 thru January
1964)

CONTENTS

	Page No.
<u>EDITORIAL POLICY NOTICES</u>	
1. Current Publication Plan	1
2. Editorial	1
3. Contributions	1
4. Circulation	1
<u>COMPUTING CENTERS</u>	
1. National Bureau of Standards, National Standard Reference Data System, Washington 25, D. C.	2
2. National Bureau of Standards, Omnitab, Washington 25, D. C.	4
3. U.S. Navy Aviation Supply Office, Inventory Control Advances, Philadelphia 11, Pennsylvania	6
4. U.S. Navy Finance Center, IBM 1401/1404/7070 Systems Application, Cleveland 14, Ohio	7
5. U.S. Navy Finance Center, IBM 1401/1404 Satellite Computer System Uses Modified IBM Multiple Duty Program, Cleveland 14, Ohio	9
6. U.S. Weather Bureau, General Circulation Research Laboratory, Washington 25, D. C.	10
<u>COMPUTERS AND CENTERS, OVERSEAS</u>	
1. The English Electric Company Ltd., Process Control Computer System, London, W.C.2., England	13
2. Ferranti Ltd., Atlas 2 Computer, London W1, England	13
3. General Post Office, LEO 326 and LEO III Computers, London E.C.1, England	16
4. Institute of Technology, Computing Center, Karlsruhe, Germany	17
5. LEO Computers Ltd., LEO III, London W2, England	17
6. Instytut Maszyn Matematycznych, ZAM 2, Warsaw, Poland	21
7. Shape Air Defence Technical Centre, Computing Center, The Hague, Netherlands	23
8. Standard Elektrik Lorenz A.G., DT 12 Data Transmission System, Stuttgart, Germany	23
<u>MISCELLANEOUS</u>	
1. Computing Devices of Canada Ltd., Tactical Moving Map Display, Ottawa 4, Canada	27
2. National Bureau of Standards, Projects FIST and SAFARI, Washington 25, D. C.	29
3. National Bureau of Standards, Foreign-Currency Scientific Program, Washington 25, D. C.	31
4. National Bureau of Standards, Real Printing, Washington 25, D. C.	31

This document has been approved for public release and sale; its distribution is unlimited.

D D C
OCT 16 1963
RECEIVED

Approved by
The Under Secretary of the Navy
25 September 1961

NAVEXOS P-645

Reproduced by the
CLEARINGHOUSE
for Federal Scientific & Technical
Information Springfield Va. 22151

Editorial Policy Notices

CURRENT PUBLICATION PLAN

Because of staffing problems the Digital Computer Newsletter was not published in October 1962 and during 1963. Commencing with this issue, however, the normal quarterly schedule is being resumed.

To assist our readers in maintaining continuity in the state of the art, this issue is devoted entirely to material scheduled for previous issues. The April 1964 issue will be largely current contributions, but there will still be some earlier submissions which could not be included in this issue.

EDITORIAL

The Digital Computer Newsletter, although a Department of the Navy publication, is not restricted to the publication of Navy-originated material. The Office of Naval Research welcomes contributions to the Newsletter from any source. The Newsletter is subjected to certain limitations in size which prevent publishing all the material received. However, items which are not printed are kept on file and are made available to interested personnel within the Government.

DCN is published quarterly (January, April, July, and October). Material for specific issues must be received by the editor at least three months in advance.

It is to be noted that the publication of information pertaining to commercial products does not, in any way, imply Navy approval of those products, nor does it mean that Navy vouches for the accuracy of the statements made by the various contributors. The information contained herein is to be considered only as being representative of the state-of-the-art and not as the sole product or technique available.

CONTRIBUTIONS

The Office of Naval Research welcomes contributions to the Newsletter from any source.

Your contributions will provide assistance in improving the contents of the publication, thereby making it an even better medium for the exchange of information between government laboratories, academic institutions, and industry. It is hoped that the readers will participate to an even greater extent than in the past in transmitting technical material and suggestions to the editor for future issues. Material for specific issues must be received by the editor at least three months in advance. It is often impossible for the editor, because of limited time and personnel, to acknowledge individually all material received.

CIRCULATION

The Newsletter is distributed, without charge, to interested military and government agencies, to contractors for the Federal Government, and to contributors of material for publication.

For many years, in addition to the ONR initial distribution, the Newsletter was reprinted by the Association for Computing Machinery as a supplement to their Journal and, more recently, as a supplement to their Communications. The Association decided that their Communications could better serve its members by concentrating on ACM editorial material. Accordingly, effective with the combined January-April 1961 issue, the Newsletter became available only by direct distribution from the Office of Naval Research.

Requests to receive the Newsletter regularly should be submitted to the editor. Contractors of the Federal Government should reference applicable contracts in their requests.

All communications pertaining to the Newsletter should be addressed to:

GORDON D. GOLDSTEIN, Editor
Digital Computer Newsletter
Information Systems Branch
Office of Naval Research
Washington, D. C. 20360

Computing Centers

National Standard Reference Data System

National Bureau of Standards
Washington, D. C. 20234

The National Bureau of Standards has been given responsibility for administering the National Standard Reference Data System recently established by the Federal Council for Science and Technology. The System will provide critically evaluated data in the physical sciences on a national basis, centralizing a large part of the present data-compiling activities of a number of Government agencies.

The National Standard Reference Data System represents an attempt to solve an important part of the general problem of communicating scientific information to users. Its aim is to develop a storehouse of standard reference data to assist in the advancement of science, technology, and the national economy. This result is to be achieved through a broad-based, comprehensive effort by scientists both in and outside government.

"Standard reference data" is defined to mean critically evaluated data on the physical and chemical properties of materials, authoritatively documented as to reliability, accuracy, and source. Tabulations of such data are of great value to the scientist or engineer who is designing an experiment or equipment, for the individual worker is thus relieved, in part, of the necessity of searching the literature and attempting to evaluate data in fields in which he is not expert. Also, through study and analysis of standard reference data, areas of science in which additional work is needed become more clearly defined, and relationships not previously apparent are recognized.

Unfortunately it is often difficult or impossible to locate the data that are needed for a specific use. In a recent study by the American Institute of Chemical Engineers,¹ three commonly used sources² of standard reference data were analyzed in terms of the availability of

data on 16 important properties (such as specific heat, viscosity, thermal conductivity, and vapor pressure) for 13,150 compounds. The average percentage of compounds for which data were available covering any property was 5 percent, and for only one property were as many as 11 percent of the compounds covered. Undoubtedly many additional data on these compounds exist in the literature, but until they have been evaluated and compiled they are of little value to scientists and engineers as a whole.

The National Bureau of Standards, as well as other organizations in this country and abroad, has been active in the compilation of standard reference data for many years. However, in view of the great accumulation of unevaluated data over the past few years, the present accelerated production of new data, and the urgent needs of American science and industry, it has become apparent that a substantially greater effort, planned and coordinated on a national basis, is needed.

The National Standard Reference Data System (NSRDS) will consist of a National Standard Reference Data Center at NBS, and various other Standard Reference Data Centers in other Government agencies and at universities, research institutes, and other non-Government organizations. In order for such centers to be a part of the NSRDS, they will be required to meet quality standards established by NBS. However, the independent and operational status of existing critical data projects will be encouraged.

The initial emphasis for establishing new standard data compilation projects will be in subject-matter areas where no effort is now being applied or where the existing effort falls far short of meeting important needs of government, science, or industry.

¹R. A. Peterson, W. M. Carlson, N. E. Dahl, and R. H. McBride, "Roadmap to Physical Property Correlations," Am. Inst. of Chemical Eng. National Meeting, Cleveland, Ohio, May 7, 1961.

²Chemical Engineering Handbook, edited by J. Perry (McGraw-Hill, 1950); Handbook of Chemistry and Physics, 41st ed. (Chemical Rubber Publishing Co., 1959-60); and International Critical Tables (McGraw-Hill, 1927-29).

An Advisory Board will review and recommend policy relative to the operation of the NSRDS. It will include, among others, representation from the National Academy of Sciences, National Science Foundation, and Federal agencies engaged in research and development.

The NSRDS will be conducted as a decentralized operation across the country, with central coordination by the National Bureau of Standards. As presently planned, the program will consist of three parts: an input from scientists in many different locations, a central source of the evaluated data at NBS, and an output system geared to the needs of the nation's scientists and engineers.

Input

The input will come from scientists who are comprehensively reviewing the literature in their fields of specialization and critically evaluating the data for ultimate inclusion in the storehouse of standard reference data. These scientists may be in universities or in industrial or Government laboratories; some will be at NBS. They will work singly or in small groups oriented to the traditional scientific disciplines. At the same time other scientists, similarly located, will be engaged in experimentally determining the standard reference data that do not exist in the literature. Clearly, the interplay between the two groups must be close and continuous.

Central Core

The central core will consist of the Standard Reference Data Center at NBS, where the evaluated data will be located, in punched cards, on magnetic tape, in notebooks, in many other forms, all mechanized for storage and retrieval. A review and control office will label the incoming data as to relative quality and reliability. The SRD Center will classify the data into as many major and minor categories as are required by the needs of the data users.

Output

The output will take the form of a series of services aimed at different technical levels and tailored to the needs of various segments of industry. In general, it will be oriented toward the application of the data, rather than toward a field of science. According to present plans,

the output services will be provided by the SRD Center and will eventually include:

1. Periodical Service designed to keep the user up to date on new data acquisitions in the SRD Center. It will provide information on the data available in the Center (but will not provide the data themselves) by means of a monthly newsletter and by annual and semiannual reviews of data acquisitions.

2. Subscription Service in which the user pays to receive all available data on a specific subject on a continuing basis. These data packages will be designed to meet the needs of specific industries, industry groups, or Government research and development programs.

3. Referral Service which will handle narrow, one-time requests for data by referral to the files of the SRD Center. In general, this service will take care of needs that are not met by the other output services.

4. Correlation and Prediction Service for computing values wherever possible in areas where some data exist, but where requests come in for specific information not contained in the SRD Center. Values will be computed by making use of correlations based on molecular structure and the properties of related compounds.

5. Mathematical and Statistical Service which will offer mathematical and computer techniques to customers for evaluating new data for subsequent inclusion in the files of the SRD Center or for individual use. This service will also provide techniques to assist in the Prediction and Correlation service.

6. Aperiodical Products including tabulations, review monographs, review papers, computer card decks, and computer tapes. These will constitute the formal end products of the SRD Center.

7. Summary Reviews to provide a rapid assessment of the state-of-the-art in fields where there are few data but which must suddenly be explored because of scientific breakthroughs or crash programs.

In planning the details of the program, the needs of American industry, academic scientists, and Government laboratories must all be ascertained and taken into account. Undoubtedly limitations in funds and manpower will require

establishment of a priority system of some kind. In choosing work to be undertaken from such a vast field, the Bureau will be assisted by the Advisory Board, interagency panels, expert consultants in the subject-matter areas, and working committees of the scientific and engineering societies, and industry associations that are active in the field of critical data.

It is expected that ultimately a large fraction of the senior scientists at the Bureau will participate in the work. In addition, the Bureau plans to invite distinguished scientists to spend some months at the Bureau, using its technical, administrative, and information retrieval services for the purpose of producing critical reviews and compilations.

OMNITAB

National Bureau of Standards
Washington, D. C. 20234

OMNITAB, a computer program that permits scientists and others unfamiliar with programming to communicate with a 7090 computer using simply written sentence commands, has been developed by the National Bureau of Standards, U.S. Department of Commerce. OMNITAB, the work of Joseph Hilsenrath, Philip J. Walsh, and Guy G. Ziegler of the Bureau staff, is used for the calculation of tables of functions, for solutions of non-linear equations, for curve fitting, and for statistical and numerical analysis of tabular data. The ease with which OMNITAB provides access to the computer makes it a tool that will pave the way to more rapid computation of routine laboratory problems.

Most computers require that a program (or code) be prepared before even a relatively simple problem can be run. These are usually formulated by a specialist. The necessity to learn a programming language forms a bottleneck in the man-machine system. This is especially true for university students and for the average experimental or theoretical scientist or engineer. OMNITAB removes this bottleneck by allowing the user to communicate with the machine directly through simple sentences made up of numbers and familiar English words.

OMNITAB was designed and written primarily for those persons whose problems are normally performed on desk calculators. An underlying motive for its creation was to relieve these people from routine day-to-day hand computing. OMNITAB gives them a means of direct man-to-computer communication in a language they best understand. OMNITAB, however, is by no means restricted to this special group of personnel—it can also be a valuable aid to professional programmers. With OMNITAB, various sections of problem analysis can be checked independently in order to determine proper programming procedures, data can be

checked for validity, and one-shot jobs can be done with a working program.

OMNITAB, by allowing the user to prepare his own data for processing, has accomplished several useful ends:

1. The computer is now as readily available as a desk calculator, because of the ease with which problems can be formulated for solution.
2. Problems that, in the past, may have been withheld from the computer because of the need for programming, can now be solved in greater detail and in less time than formerly.
3. The responsibility for the data, both its accuracy before going into the computer and the types of operations to be performed on it, now rests solely with the person who is most familiar with the problem—the scientist.
4. Programmers who formerly spent considerable time devising routines for relatively straight-forward problems will now be free to handle more important tasks.

A wide variety of mathematical and manipulative procedures are available in the OMNITAB routine. In addition to the basic arithmetical operations, there are provisions for raising to powers, use of logarithms to base 10 and base e, elementary and special functions, curve fitting, integration, differentiation, interpolation, and many others. The program has a capacity of 7200 results, arranged in 36 columns of 200 rows each.

A "statistical analysis" package, which computes the average of a set of numbers (200 maximum) and 30 statistical measures related to the average, dispersion, randomness, and

other properties of the distributions, has been incorporated in the program. This analysis, which takes only a fraction of a minute on the machine, should have a beneficial standardizing influence on the statistical analysis of laboratory data.

The instructions to the computer, as well as the data to be manipulated, are prepared for entry to the machine on punched cards. Simple sentences are used to indicate the allowed operations. For example, one instruction in a series might read

MULTIPLY COLUMN 3 BY COLUMN 4,
STORE IN COLUMN 5,

or, in abbreviated form

MULTIPLY 3 BY 4, STORE IN 5,

or even shorter still as

MULTIPLY 3, 4, 5.

The figures in a column can be operated on by those in another column or by constants. The presence of a period after a number indicates that the number is to be read as itself, whereas the absence of a period indicates a column of numbers. Thus the two sentences

ADD 2. TO 3, STORE IN 4; and, ADD 2 TO
3, STORE IN 4

have different meanings. In each instruction, the last figure indicates a column in which the results are stored. Each sentence gives a unique command for a specific type of operation, a series of commands being necessary for the computation of a problem (see attached example).

The result of an operation can be stored in a column or added to the data already in a column. Differentiation of these two procedures is accomplished by the inclusion of an extra "MULTIP." term to provide cumulative multiplication. For example,

MULTIPLY COL 2 BY COL 3, STORE IN
COL 4

will result in the product of this operation being cut in column 4 by clearing that location prior to storage.

MULTIPLY COL 2 BY COL 3, MULTIPLY
BY 1., ADD TO COL 4

instructs the computer to add the product to data already in column 4.

Function generation is achieved by such sentences as:

LOGE OF COL 4, MULT COL 2, ADD TO
COL 7;

ERROR FUNCTION OF COL 1, MULT BY
1.8735, STORE IN COL 5; and

TAN OF 1.8 RADIANS, MULT BY COL 3,
ADD TO COL 7.

Other mathematical operations are obtained by such sentences as:

STATISTICAL ANALYSIS OF COL 3,
WEIGHTS IN COL 2;

DERIVATIVES OF COL 2, USE 5 POINTS,
H = 1., STORE IN COLS 3, 4, 5;

FIT COL 2, WEIGHTS IN COL 3, VECTORS
IN COLS 1, 4, 5, 6;

POLYFIT COL 2 WEIGHTS IN COL 3, USE
5TH DEGREE POLYNOMIAL;

PLOT COLS 2, 3, 4, 5, 6, AGAINST COL 1;
and

DIFFERENCE COL 3.

Additional features of the program include a variety of manipulative operations, flexible input and output formats, and options to punch cards, plot graphs, abridge tables, and the like. Finally, a built-in dictionary permits OMNITAB to accept instructions not only in English but in French, German, and Japanese as well.

A typical problem and the OMNITAB instructions for its solution are presented in Table I.

Table I. Typical Problem and
OMNITAB Instructions

Compute the Einstein functions:

$$-G = -\ln(1 - e^{-x})$$

$$H = xe^{-x}(1 - e^{-x})^{-1}$$

$$C = x^2e^{-x}(1 - e^{-x})^{-2}$$

$$S = -G + H$$

for $x = .01(.01)2$.

List of OMNITAB Commands

LIB 7,10000

IDENTIFICATION HILSEN RATH 4-19-62
TITLE 1 EINSTEIN FUNCTIONS
GENERATE .01(.01)2.00 IN COL 1
NEGEXP OF COL 1, STORE IN COL 2
MULTIPLY COL 2 BY -1. STORE IN 3
ADD 1. TO COL 3 STORE IN 3
LOGE OF COL 3, MULT BY -1., ADD INTO 4

RAISE COL 3 TO -1., MULT BY COL 2, ADD 5
MULTIPLY COL 5 BY COL 1, STORE IN 5
ADD COL 4 TO COL 5 STORE IN COL 6
DIVIDE COL 5 BY COL 2, MULT BY 5, ADD 7
HEAD COL 1/ X
HEAD COL 4/ G
HEAD COL 5/ H
HEAD COL 6/ S
HEAD COL 7/ CSUBP
FIXED POINT 5 DECIMALS
PRINT 1,4,5,6,7

Inventory Control Advances

*U.S. Navy Aviation Supply Office
Philadelphia, Pennsylvania 19109*

Some of the most advanced techniques in electronic accounting systems are being developed by the U.S. Navy Aviation Supply Office (ASO), in Philadelphia. This inventory control point has, as its primary mission, the supplying of hundreds of thousands of spare parts to Navy and Marine aircraft throughout the world. In order to refine procedures and techniques to perform its mission effectively, ASW has devised an impressive data processing system. This system has resulted from the imagination and hard-won experience of a battery of management and automatic data processing specialists. They have permeated the thinking of ASO administrators, and have been tremendously effective in the support of the Fleet. The considerable effectiveness of the new techniques is illustrated in the automation of three major areas of the Supply function: Purchasing, Inventory, and Requisitioning.

Purchasing

In March 1963, ASO became the first Federal agency to automate the processing of small purchase orders required for stock replenishment. Automated procedures on a combination IBM 1401/1410 computer system were implemented which have routinized, simplified, and expedited the processing of thousands of small-dollar procurements, and have eliminated countless manual processing steps.

Almost 80 percent of the item buys ASO makes each year are under \$2,500 per item. The number of individual item buys is steadily increasing, as a result of stringent fund restrictions, and the increase in the number of parts used in complex modern weapon systems. While these item buys constitute only a small

percentage of the dollars spent on the repair part support of Naval Aviation, they have resulted in a maze of paperwork and many man-hours of effort.

The new system electronically collates replenishment requirements with available suppliers. This dovetailing of information produces Request for Quote EAM cards for each item and destination. The cards are sent to the pertinent suppliers, who affix prices, delivery dates, and discount terms, and return them to ASO. They are then reviewed by procurement agents located in the electronic computer area to determine acceptability of the quotations (the only human decision in the process). Acceptable quotes are batched weekly and fed back into the computer to produce an eight-part, continuous-feed purchase order. A facsimile signature is mechanically affixed to the purchase order in this latter operation.

As a result of the new procedure, the 10 to 15 pieces of paper which usually found their way into a contract folder for a small purchase have been reduced to only 2. The annual workload on the printing presses will be reduced by at least 2,500,000 sheets. The manual review and document preparation actions which will be eliminated number in the hundreds of thousands annually.

Automation has produced the most expedient and efficient small purchase system to date, and has allowed valuable purchase talent to be applied to the large-dollar buys.

Information Storage and Retrieval System

For computer inventory control operations, the trend is turning away from the magnetic tape

as the principal data storage medium and towards the magnetic disc or drum, because of the almost instantaneous accessibility of the latter, provided the number location or address is known. The random access capability is essential in the processing of daily transactions, which arrive in no ordered sequence, or in the rapid compilation of a list of associated items which are scattered throughout the files.

ASO has pioneered the latest techniques by participating in the pilot operation of a real-time data storage and retrieval system developed at the University of Pennsylvania's Moore School of Electrical Engineering, under contract to the Navy's Bureau of Supplies and Accounts and the Office of Naval Research. This system, known as the Multi-List, solves the problem of addressing individual stock items. It also provides, through address linkage, lists of stock items associated by a common characteristic but physically scattered through the file.

Applying this theory to the capabilities of the IBM 1405 Disc Storage Unit attached to a medium scale 1401 computer, ASO programmed a data retrieval system, during the latter part of 1962 which provides instant access to any stock item in the file through the Federal Item Identification Number, the Manufacturer's Part Number, or other keys. It gives immediate response to a request for inventory stock status or a request for technical information on such matters as engineering, units per application, production lead time, and similar areas of supply and technical data. It produces the answer on the console typewriter, or it can display it on one of many small television-type screens located at various distances from the computer. It responds to a request for any desired weapons list breakdown with a listing on the printer, containing the stock numbers of all component assemblies with pertinent technical data, along with up-to-date stock status information. An almost human quality of the system is its ability to make decisions as to the relative importance of a group of queries, and its capacity to deflect less important items in favor of those with higher priority. The system can receive, and store for future action, up to 34 requests, while answering higher priority queries.

IBM 1401/1404/7070 Systems Application

*U.S. Navy Finance Center
Cleveland, Ohio 44100*

Systems Application

The addition of an IBM 1401/1404 computer configuration as a satellite to the U.S. Navy Fi-

Automatic Interim Requisitioning

The success of the random retrieval experiment has started an accelerated program of advanced automated techniques to harness the speed of the new system to other supply procedures. Using a much larger IBM 1301 Disc Storage Unit attached to an IBM large scale 1410 computer, it has provided automatic processing in a certain range of the interim consumable parts requirements (approximately 350,000 items in number) without manual intervention. As each field requisition is fed into the computer system from the transceiver network, it searches out activities which are storing supply material not required for local needs, and based on a geographical proximity table, it automatically prepares the shipping directive to have the material sent to the requiring activity. This directive is transmitted by way of transceiver network to both the shipping and receiving activities.

Some 30 to 40 percent of current interim requests are now being automatically processed, but proposed alterations to the system will widen the range and increase the rate to 60 percent, allowing supply managers to concentrate more effectively on the more troublesome items. Even when these are passed along by the computer for personal attention, automation helps by supplying price and other information, thereby reducing the quantity of manual screening required. Moreover, in the near future supply managers will have remote inquiry stations to tap the computer storage for up-to-the-minute inventory and file information. The answers to their requests for specific data will be displayed instantaneously on the screens, or printed on hard copy printers.

These automatic procedures are also used on the periodic Consolidated Stock Status Reporting (CSSR) redistribution. Each week a segment of the consumable parts inventory is analyzed for redistribution purposes by item and by activity. This results in a report that shows for each stock item which activities have excesses and which have net requirements. When this information is fed into the automatic processing procedures, shipment requests are produced that will supply 50 to 60 percent of the activities in short supply, and this is done within a matter of hours instead of the 20 days allowed under manual processing schedules.

nance Center's IBM 7070 system is unique in that for \$2,000 less total monthly computer rental, the new system will perform all the old functions with greater flexibility and in less

elapsed time, freeing computer hours for other applications.

Within 6 months after it installed its IBM 7070 computer (in September 1960), the Cleveland-based Finance Center had two of its major applications, military allotments of pay and military pay record processing, on the machine. And in less than 1 year the third application, monthly payments to all U.S. Navy Retired and Fleet Reserve personnel, was added to make the system 100-percent operational. The allotment master tape file has one million accounts and disbursements of \$116 million are made monthly. The retired pay master file has 128,000 accounts and disbursements of \$23 million a month. Each year 1,600,000 military pay records are reviewed by the computer. The Finance Center's conversion from a combination Addressograph plate, IBM stencil, and EAM system to the 7070 was highly successful and for the past year the Center has been processing 100,000 input documents a month and issuing 600,000 card checks and bonds a month at an annual savings of more than \$150,000—and with greater efficiency and accuracy.

The initial 7070 system, with two input-output channels and a 5000-word memory capacity, had peripheral equipment on-line consisting of eight tape drives, a card reader, two card punch machines, and three IBM 408 printers with bill-feed attachments. This configuration was unique in that relatively slow-speed printers (IBM 408's - 150 lpm) were connected directly to the computer. This, however, was necessary since high-speed printers for printing card checks were not then available. The immediate solution was to use three 408 printers on line, printing two checks per printer and using the priority features of the 7070 equipment to achieve a rated print speed of 900 lines per minute.

In July 1961, a study was made to determine the benefits which could be realized with a satellite computer to perform the input-output operations (card-to-tape and tape-to-printer or punch). At about the same time, information was received that the IBM 1403 printer (600 lines per min) was being modified to print card checks for the Treasury Department. Investigation of this new equipment for handling card checks at the Finance Center revealed that the voluminous check print and print operations as

well as other input-output operations could be performed on a 1401/1404 configuration at a reduced production cost. The study also revealed that a savings of about \$2,000 per month could be realized through reduced rental of equipment and number of operating personnel required. A recommendation was made to replace the 7070 peripheral unit-record equipment with an IBM 1401 computer system having a 1402 card reader/punch and a 1404 printer, capable of printing either on EAM cards or continuous form paper.

The Department of Defense approved the recommendation for the 1401 satellite computer on February 21, 1962 and appointed the Navy Management Office to conduct a Readiness Review, which was held at the Navy Finance Center on May 1 and 2, 1962. In September 1962 the computer was installed and placed into operation immediately following a system test to assure that programs previously tested functioned satisfactorily on the new configuration.

In addition of a 1401 computer results in a tape-oriented 7070 system with a console card reader and eight tape drives on line. Initially, the 1401 will be used primarily as a "slave" to prepare tapes for use on the 7070, and to punch or print output requirements. Except for writing programs for punching and printing checks, the Navy Finance Center plans on using a multiple duty program, furnished by IBM for most of its requirements. The multiple duty program has the facility to perform card-to-tape, tape-to-punch or tape-to-printer operations, individually, in any combination desired, or all three operations simultaneously. With this program, the card read time or print time can be overlapped with punch time, resulting in completion of two or more operations in less time than it would take to do them separately.

In addition to the \$2,000 per month savings, the addition of the 1401/1404 has greatly increased the flexibility of the NFC data processing system and released considerable prime shift time on the 7070 for processing new approved applications generated within the Center or by other Government agencies. The first of the outside jobs was put on the computer during August 1962. It consists of a management reporting system for the Office of Naval Material in Washington.

IBM 1401/1404 Satellite Computer System Uses Modified IBM Multiple Duty Program

*U.S. Navy Finance Center
Cleveland, Ohio 44106*

Multiple Duty Program

When the U.S. Navy Finance Center, Cleveland, Ohio, installed an IBM 1401/1404 computer system as a satellite to its present IBM 7070 system, it employed a modified IBM 1401 multiple duty program to achieve maximum usage and optimum operating speeds.

The program, #1401-UT-039, permits card-to-tape, tape-to-card, and tape-to-printer operations to run simultaneously in any combination and to start or conclude any operation while others continue. The program is made up of six independent, but inter-connected routines of binary coded decimal (BCD) card-to-tape, BCD tape-to-card, tape-to-printer, pure binary card-to-tape, pure binary tape-to-card, and a rapid card-to-tape or tape-to-printer routine.

The Navy Finance Center has modified the program to provide for tape labels and permit modifications for specialized routines while retaining the option to perform more than one operation. The program was modified as follows:

1. Card-to-Tape
 - a. Increase blocking factor from one to five
 - b. Provide operator option to write or not write tape header and trailer records (labels)
2. Tape-to-Card
 - a. Accept labeled or unlabeled tape
3. Tape-to-Printer
 - a. Accept labeled or unlabeled tape
 - b. Allow printer skip and space codes for both before and after print rather than just before print.
 - c. Read pre-punched savings bond card stock from the 1404 bill feed printer and compare with tape record data.
4. Provide typewriter input and output
5. Binary routines
 - a. Remove both card-to-tape and tape-to-card binary routines.

Basic program material consists of a condensed program card deck, system listing, operating instructions, and flow charts. A source symbolic program deck is available from IBM, as optional program material, upon request.

Operating speeds, involving both high and low density tapes, experienced during testing and debugging the modifications made to the program verified the speeds reported by IBM. Possible speeds for various configurations are as follows:

- | | | |
|----------------------------------|----------------------------------|-----------------------------------|
| 1. Card-to-Tape | Blocked One,
BCD &
Binary | 800 Cards/min |
| 2. Tape-to-Card | Blocked One,
BCD &
Binary | 250 Cards/min |
| 3. Tape-to-Printer | Blocked One,
Single
Spaced | 600 Lines/min |
| 4. Concurrent
Card-to-Tape | Blocked One | 500 Lines/min |
| | Tape-to-Printer | |
| 5. Concurrent
Card-to-Tape | Blocked Two
or More | 530 Lines/min |
| | Tape-to-Printer | |
| 6. Concurrent
Card-to-Tape | Blocked One | 275 Lines/min |
| | Tape-to-Printer | Blocked One 275 Lines/min |
| | Tape-to-Card | Blocked One 145 Cards/min |
| 7. Concurrent
Card-to-Tape | Blocked One,
BCD | 325 Cards/min |
| | Tape-to-Card | Blocked One,
BCD 160 Cards/min |
| 8. Concurrent
Tape-to-Printer | Blocked One | 325 Lines/min |
| | Tape-to-Card | Blocked One,
BCD 160 Cards/min |

The program may be interrupted at any time to introduce another operation by pushing the interrupt button on the 1401. At that point, the effective speeds for the applicable configuration listed in 4 through 8 above would prevail. As soon as one of these operations is completed, speeds will automatically increase to that of the configuration remaining.

The versatility of IBM multiple duty program #1401-UT-039 is such that NFC is able to load this basic program in their satellite computer at the start of a day and perform a variety of operations throughout the day without having to change programs.



General Circulation Research Laboratory

U.S. Weather Bureau
Washington, D. C. 20235

The goal of the General Circulation Research Laboratory is to expand man's basic knowledge of the atmosphere. Specifically, its purpose is to express accurately the physical laws that govern atmospheric behavior.

In the Laboratory, Weather Bureau scientists are seeking the answers to many questions. Why does the atmosphere respond in the way it does to energy from the sun? How and why does the atmosphere transform this energy from the sun through various stages before it is ultimately dissipated? Of all the possible motions that one can imagine in a fluid such as the atmosphere, why do we observe only a few? What is the relationship between the circulation in the Northern and Southern Hemispheres? How are the stratosphere and lower atmosphere coupled? To what extent do variations of the earth's surface determine our climate? Are variations of the sun's radiation a significant factor in the weather we experience? If man is to modify the weather or even to forecast it for long periods in advance, these questions and many others must be answered.

The atmosphere is a fluid so vast that there are two million tons of it for each person on earth. Yet 99 percent of the atmosphere—or five billion million tons—lies within 19 miles of the earth's surface, encasing the globe like a thin skin. This ocean of air is always in motion, driven by energy from the sun. Heated more at the equator and less at the poles, the atmosphere constantly tries to equalize its temperature and in the effort creates wind and weather. The winds and the weather are steered by the earth's rotation and, as they move around the earth, they are also affected by the topography—mountains, plains, and oceans. The result is an amazing complexity of weather events—events that never repeat themselves exactly.

Developing Techniques For Studying the Atmosphere

Since the meteorologist obviously cannot study and observe the entire atmosphere, he brings into his laboratory a hypothetical atmosphere in the form of differential equations expressing the basic physical laws. The methods used by the General Circulation Research Laboratory trace their origin back to Isaac Newton who formulated the fundamental laws of particle dynamics. Later theorists extended these laws to cover fluid motion and applied them to studies of the atmosphere.

At the beginning of this century, V. Bjerknes of Norway foresaw the possibility of using laws of fluid motion for weather forecasting. In 1922, Lewis Fry Richardson, an English mathematician, suggested specific means for accomplishing this, but he estimated that 64,000 people would be needed to analyze weather observations and prepare forecasts by this method, which is now called numerical weather prediction. In Richardson's day there were no electronic computers and, in any case, the structure of the atmosphere was not yet known well enough to use his method successfully.

In the late 1930's and early 1940's, more sophisticated theories applicable to numerical forecasting were formulated by a number of outstanding scientists. Carl-Gustaf Rossby, a noted Swedish-American meteorologist, developed a formula for predicting the speed of westerly waves high in the atmosphere. Simply stated, the speed of a wave depends on the wind speed, the size of the wave, and its latitude.

During the same period, other scientists were constructing the first high-speed digital computers. With the development of the computer and the theory of westerly waves, numerical weather forecasting became a practical

possibility. The actual techniques were developed at the Institute for Advanced Study in Princeton, New Jersey, under the direction of Dr. J. von Neumann and Dr. Jule Charney.

These techniques, developed for the purpose of short-range weather prediction, soon showed their potential for the study of longer period evolutions of the earth's atmosphere. At the Institute for Advanced Study, Dr. Norman A. Phillips undertook the first "numerical" study of the atmosphere's general circulation, using hydrodynamical equations to represent atmospheric motion and employing an electronic computer to carry out the calculations.

In 1954, Dr. von Neumann urged the Weather Bureau to begin theoretical studies of the general circulation, and the General Circulation Research Section was established by the Bureau in October 1955. (The name was later changed to General Circulation Research Laboratory.) Its aim was to develop a theoretical framework capable of reproducing and explaining the response of the atmosphere to the energy received from the sun.

Creating a Model Atmosphere

In constructing a hypothetical atmosphere or mathematical model, scientists must first select a system of physical laws that are assumed to be most important in determining atmospheric movements and evolutions. The physical laws are next expressed in differential equations, which are analyzed numerically and programed as instructions for the computer. The complexity of the model is limited by the capacity of the computer to be used. The early models described the motions of the atmosphere as simply as possible and still stretched to the limit the capacity of the computers then in use.

The computer solves the mathematical formulas and calculates the movements of the atmosphere over a series of time intervals or "time steps." That is, upon obtaining the forecast over the first time interval, this result then is used to proceed to the next, and so on. For purposes of calculation, the earth is divided into rectangular grids, and the equations must be solved at every point on the grid for every time step.

The hypothetical model of the atmosphere is not considered to be correct unless it realistically simulates possible atmospheric behavior over extended periods of time.

The testing of a model can take several years, depending on its complexity. If it produces

impossible results—weather that has never been observed—the scientists must painstakingly search for the errors in their calculations or in their theory.

The Laboratory's Models

The models of the atmosphere devised by the General Circulation Research Laboratory have been designed to simulate the characteristics of an atmosphere in increasing degrees of reality. The six models have been designated Mark I through VI.

The first model, Mark I, was limited to the motions of the atmosphere between the equator and 64° N. latitude, using only two atmospheric levels and only 1300 grid points in each level. The vertical structure of this model atmosphere was described as simply as possible while still permitting the development of storms. The model ignored the effects of cloud formations and precipitation on the evolutions of the atmosphere, and highly simplified the way that solar energy is made available to the atmosphere. Mark I has successfully accounted for some of the most important gross properties of the atmosphere's wind systems, the large-scale characteristics of middle latitude storms, and the role that they play in maintaining the heat balance of the atmosphere against the sun's radiant energy.

All of the Laboratory's later models, the ones being worked on currently, are global in scope. Mark VI, with 10,000 grid points in each of 10 levels including the earth's surface, permits more detailed descriptions of what is happening in the atmosphere than earlier models. It allows a close approximation of the solar energy absorbed and reemitted by the earth and the atmosphere. Also, it takes into account the surface features, evaporation, snow cover, cloud formation, and precipitation, so that the atmospheric evolutions should be calculated more precisely than with earlier models.

Additional Research

The Laboratory's scientists sometimes find that in order to add the correct elements to their mathematical models they must have a better understanding of certain atmospheric processes. They have therefore undertaken additional research to learn how the atmosphere absorbs and transmits radiant energy, how the clouds and precipitation of large storms are formed, why and how the cumulus clouds of thunderstorms are formed, the effects of large

mountain masses and of the irregular distribution of land and water over the globe, and how the oceans exchange energy with the atmosphere.

Studies Benefit Forecasting

The research of the General Circulation Research Laboratory has produced by-products that are useful in solving forecasting problems. The first numerical method of forecasting precipitation amounts was developed in the Laboratory. The Laboratory was the first to solve a system of weather forecasting equations that more exactly fit actual weather conditions than earlier methods.

Potential Results of the Laboratory's Work

In the future, more refined and realistic mathematical models will demonstrate how accurately the behavior of the atmosphere can be predicted over various long periods of time. With better models, scientists hope to solve the mysteries of climatic change. These models may one day be used to make the actual long-range weather predictions.

When theoretical models are able to reproduce natural phenomena faithfully enough to be useful in prediction, the next logical step is to investigate weather modification, inadvertent as well as intentional. Where and how is the atmosphere sensitive to external influences?

Could its behavior be altered with the relatively small sources of energy available to man? Through simulation in the theoretical models, the scientists will learn what would happen to world weather and climate if, for example, artificial clouds could be created to reflect more sunlight away from the earth; if more carbon dioxide were released to the atmosphere; if more forests were converted to agricultural land or cities; or if artificial black ground cover could be introduced over large areas such as the Arctic ice pack.

Laboratory Staff and Facilities

Organizationally, the General Circulation Research Laboratory is part of the Weather Bureau's Office of Meteorological Research.

Dr. Joseph Smagorinsky has directed the Bureau's general circulation research since the establishment of the Laboratory in October 1955. Since 1955, the Laboratory's staff has grown from 2 to 36 and now includes meteorologists, physicists, oceanographers, mathematicians, programmers, and computer operators.

For nearly 7 years, the Laboratory was located in the Weather Bureau's facilities at Suitland, Maryland. From 1955 to 1957, an IBM-701 computer was used for studies of the general circulation. This computer was replaced by an IBM-704 in 1957, and then by an IBM-7090 in 1960. During the summer of 1962, the Laboratory moved to the building at 615 Pennsylvania Avenue, N.W., Washington, D. C., that houses the IBM STRETCH computer.

Computers and Centers, Overseas

Process Control Computer System

*The English Electric Company Ltd.
London W.C.2, England*

An on-line process control computer system has been ordered from the Metal Industries Division of English Electric, Stafford, by the Shelton Iron and Steel Company as part of the new universal beam and section mill project at their Etruria works, Stoke-on-Trent. The system will be based upon the KDN2 computer and will be manufactured by English Electric-Leo Computers Limited at their Kidsgrove works not far from Etruria. It will minimise the waste from cutting beams and sections into the lengths ordered by customers by optimising control of the two hot saws.

This is the first digital computer system in the United Kingdom to be used on-line for direct control of cut length at a hot saw. As a small percentage increase in yield from this type of mill will give substantial returns; it is estimated that the system will regain the capital outlay in about 12 months.

With a beam and section mill several different lengths are usually cut from each finished beam, but the length of beam rolled is not accurately known until it reaches the hot saw. It

is therefore not possible to schedule the cutting process in advance. Under manual control the sawman only has time to carry out an approximate calculation, which often results in short unsaleable lengths being left at the tail of some beams.

The high operating speed of the KDN2 system makes possible the investigation of many different combinations of order lengths in a matter of seconds. The computer then selects the solution giving the best yield, displays the lengths to be cut in sequence to the operator and automatically sets the hot saw bench and stops for each cut.

In addition to the control of the two saws, the computer tracks each bloom that is loaded into the reheat furnaces through the mill and on to the cooling beds, so that each cut length can be identified. At the cooling beds a digital display provides the cast number, and two teleprinters the order details.

Six other systems using English Electric-Leo KDN2 computers are installed or on order for the U.K. steel industry.

Atlas 2 Computer

*Ferranti Ltd.
London W1, England*

Atlas 2 is a new, smaller version of Atlas (see DCN October 1960 and October 1961), averaging half its size but with a wide choice of both size and speed. The computer offers up to 131,072 words of core store and can complete nearly half a million instructions per second. It provides comprehensive time sharing with complete program protection. The system can handle a large number and variety of peripheral equipments, with multiple operating consoles. Special purpose on-line devices present no problem. The machine is fully asynchronous. Thus future improvements in machine performance are not blocked by a fixed cycle time.

Atlas 2 and Atlas 1 (hitherto called Atlas) have an identical instruction code; programs may be written to run on either machine. Atlas 2 benefits extensively from both hardware and software designed for Atlas, and therefore represents the cumulative experience of Manchester University, Cambridge University, and Ferranti in computer design.

Storage Systems

B-Store (Access 0-35 microseconds, 128 halfwords)—This store holds indices (modifiers)

and has its own accumulator which can operate concurrently with the Main Accumulator.

V-Store—Data signals and control signals for peripherals. Lock-out control.

Main Core Store (Cycle 2-1/2 or 5 microseconds, through 4 independent access systems, 32K, 64K, or 128K words).—The core store cycle time is either 2-1/2 or 5 microseconds throughout. The independent access systems permit the overlapping of instructions, successive commands being routed through separate systems. The Main Store is only sub-divided for program requirements. Each program is allocated a multiple of 512 words by the "Supervisor" (see below); at any moment there may be several programs present in the main store. There are provisions for lock-out regions within a program, for peripheral transfers or other purposes.

Slave Store—There are 40 extremely fast access registers constructed of tunnel diodes.

Fast Operand Registers—In 32 of these, small loops of instructions are automatically stored while they are obeyed; any loop of less than 64 instructions benefits from this facility. The remaining eight registers are provided for use as fast working space by programs. The double merit of these 40 registers is that they reduce store access time effectively to zero, and also relieve the core store access systems.

Magnetic Tape System—Although strictly a peripheral, the magnetic tape system contributes to the internal store of the machine in that the Supervisor assembles programs onto magnetic tape, where they wait to be executed. All magnetic tape transfers, whether of programs or data, occur in units of 512 words (one block). The block may start at any core store address, and may even be scattered over the store in a number of sub-blocks. A channel facility is provided which gives automatic buffering and lock-out during a transfer. Magnetic tapes on Atlas 1 and Atlas 2 are compatible.

Words and Instructions—Words are 48 bits long. Each instruction occupies one word. Floating-point numbers of the form $x.8^y$ have an 8-bit signed exponent, and a 40-bit signed mantissa, equivalent to about 12 decimal digits. The octal exponent speeds shifting. Words may be used to hold eight 6-bit characters, numbered 0 to 7.

Addresses are 21 bits long; of these, 3 determine the type of address (relative, absolute,

V-store, and so on). In addition three further bits address a character within a word. A programmer may only use relative addresses, the base address being determined by the Supervisor Program. The index register numbers Ba and Bm are referred to in an instruction. This permits double modification of arithmetic instructions and two-address indexing instructions. The instruction format is as follows:

Function	Ba	Bm	Address	Character
10 bits	7 bits	7 bits	21 bits	3 bits

A typical arithmetic operation is:

0820, 51, 52, 1234

add the floating point number in register 1234 + i + j to the accumulator and round off, where i and j are the contents of index registers 51, 52'.

Speeds—The time taken by instructions depends very much on the context because of instruction overlap, multiple access to the store, and the use of the slave store. An approximate guide is given below (time in microseconds):

Instruction	2½ microsec. store		5 microsec. store	
	In slave store	Not in slave store	In slave store	Not in slave store
Floating-point addition	2.0	2.8	2.0	4.6
Floating-point multiplication	5.0	5.0	5.0	5.5
Product of two n-vectors	11.9n	15.0n	14.3n	25.9n
Sum power series, n terms	7.4n	9.2n	8.3n	13.7n

Sequence of Operation—Normally the machine is obeying instructions taken from the mainstore. The address of the instruction being obeyed is held in the Main Control in the special purpose index register B127 in the B-store.

If, however, a complicated instruction requiring, for example, the formation of the logarithm of the number in the accumulator is required, the function digits corresponding to the function logarithm are copied into the Extracode Control Register (B126 in the B-store), and the logarithm is computed by the extracode routine, which starts at an address within the Supervisor corresponding to the address in B126. When the extracode routine is completed, control reverts to the Main Control in B127.

The extracode facility allows the basic instruction code of the machine to be augmented to include about 250 additional codes for elementary functions, input and output conversion and mixed radix conversion. In short, all the facilities normally thought of as part of a subroutine library are available in Atlas 2 as extracode functions. If a peripheral transfer terminates or if any peripheral device requires access to the computer while either main or extracode instructions are being obeyed, control is transferred to a third control register stored in index register B125, known as Interrupt Control. All peripheral transfers are initiated by extracode functions. Interrupt control is called in automatically whenever an information transfer (usually of one character, column or line) is required to enable the device to continue at full speed. The transfer is organized by a part of the Supervisor, which passes control back to the interrupted program when the unit of information concerned has been transferred. In the case of magnetic tape transfers the initiation of the transfer is handled by an interrupt routine, but thereafter the transfer and a program proceed concurrently, the transfer causing the program to hesitate when access to a word in the core store is required by the transfer.

The Supervisor Program—Permanently present in the machine is the Supervisor, whose function is the control of autonomous input and output on paper tape, cards and line printers, control of autonomous magnetic tape transfers, execution of extracodes, program scheduling and the Time-Sharing of the various parts of the machine between any number of programs currently held in the core store. The hardware and Supervisor together ensure that an error in one program cannot interfere with any other. The Supervisor reviews the priorities accorded to programs from time to time in the light of the current situation and the operator's instructions, and will occasionally move a program from one part of the store to another to allow space for a large program which has been assembled on magnetic tape. The effect of

these activities is to ensure maximum usage of the system as a whole. The Supervisor also provides monitoring information; it has two-way communication with the operator.

Automatic Programming—It is planned to provide compilers for Algol, Fortran, and Cobol.

The Peripheral System—The minimum peripheral and magnetic tape coordinators allow for equipment as shown in the following list. Double the number may be attached with extra hardware.

<u>Equipment</u>	<u>Minimum Provision</u>
Character Input Devices (tape readers, keyboard inputs)	6
Character Output Devices (tape punches, teleprinters, flexowriters)	6
Card Readers	2
Card Punches	1
Line Printers	2
Spare 24-bit channels and 12-bit channels (for special purpose on-line devices)	8 each
Magnetic Tape Units	

The basic installation will comprise:

- 1 Operators' input-output device
- 3 Paper Tape Readers
- 3 Paper Tape Punches
- 3 Off-line Flexowriters
- 2 ICT Card Readers (600 cards/minute)
- 1 ICT Card Punch (100 cards/minute)
- 1 Anelex Line Printer (1000 lines/minute)
- 8 Ampex TM2 Magnetic Tape Units (90,000 chars/second)
- 1 Creed 75 Teleprinter on-line for Magnetic Tape System
- 1 Engineers Console, consisting of
 - 1 Paper Tape Reader
 - 1 Creed 75 Teleprinter for output
- Displays and operators keys/switches.

Further peripheral devices may be attached to Atlas 2; for example, IBM compatible magnetic tape units, mass stores, graphical display units, and the like.

LEO 326 and LEO III Computers

*General Post Office
London E.C.1., England*

The Order

The G.P.O. have announced that they have placed an order with English Electric - LEO Computers Ltd. for two LEO 326 computers. The value of the order is over £1 million. It is the largest single order for commercial computing equipment ever placed in the United Kingdom. The LEO 326 computers will be delivered in 1965.

The Choice of Equipment

The G.P.O. chose LEO 326 after a stringently planned comparative survey designed to insure that the equipment chosen had the best performance in terms of data processed per unit of cost, both as regards capital cost and running costs. In arriving at their decision the G.P.O. considered proposals made by manufacturers of all large scale data processing equipment both in the United Kingdom and also in the United States and Europe. In all, nearly 20 large scale computers were studied by a team including G.P.O. mechanisation experts and Post Office engineers.

Application

Plans are being made for the computers to take in work from a number of different Post Office sources including initially work connected with repayment of National Savings Certificates, dividend payments in respect of Government stock and bonds on the Post Office Register, the operations of the Post Office Supplies Department, and Premium Savings Bonds. It is not intended to alter the present arrangements for the generation of numbers for the monthly Premium Savings Bond draws, which will continue to be done by "Ernie."

Support Services

As well as subjecting the computer system specification to close study the G.P.O. assured themselves that support of the highest quality in regard to systems planning, programming, operational assistance and maintenance could be provided by the chosen manufacturer.

The Buildup

As indicated by the G.P.O. the two LEO 326 computers will be preceded by two LEO III's (see DCN, July 1962) which they will replace. The LEO III's which are fully compatible with the LEO 326 will be used for building up the load of work prior to the arrival of the more powerful computers. Before even the LEO III's are delivered, work to prove programmes and to prepare for full scale running will be carried out on LEO Service Bureau Computers.

The LEO III

The LEO III's that will be initially used are fast transistorised computers that have been well received by industrial organisations, local government authorities, and government departments. Over 20 LEO III computers have been ordered, 7 of which have been delivered and are in operation. A large LEO III will be installed at Southend at the beginning of July for H.M. Customs and Excise. It will carry out a variety of work on import-export statistics. A major factor in the choice of LEO III for this application was the proven ability to work on several quite different jobs at the same time. Later this summer the Board of Trade will install a LEO III in the Census Office at Eastcote, Middlesex, where the main job is related to the Census of Production. Other work includes the census of retail distribution and the calculation of retail and wholesale price indices.

The LEO 326

The LEO 326 is an advanced version of LEO III, and in the form ordered by the G.P.O. will be nearly 10 times faster. It will be able to have access to its fast memory of up to 320,000 characters in approximately one millionth of a second. It can multiply two 10-digit numbers together in 53 microseconds. It can take logical decisions as to which alternative paths to follow in three millionths of a second. Among the features of LEO 326, as of LEO III, is its ability to work directly in *t.s.d.* as well as decimal or any other notation.

Magnetic Tapes

Each LEO III and LEO 326 will be equipped with a bank of magnetic tape decks which will hold the millions of records with which the G.P.O. has to deal. The G.P.O. LEO 326 will be equipped to take information from magnetic tape at the effective rate of nearly 250,000 alphanumeric characters per second. A special facility is being added to the G.P.O. computer by means of the LEO microprogramme facilities to enable the magnetic tape records to be inspected in the minimum of time to see whether information refers to a particular record. It will take 20 microseconds to know whether a particular transaction refers to the next record on the magnetic tape file.

A high density magnetic tape system, in the development of which LEO designers have played a leading part, will be used. In this system, information will be recorded on 1/2-inch magnetic tape at a density of 750 characters to the inch.

Printers

The G.P.O. work will call for a heavy load of printing. The printers employed will be able to print lines of 160 characters at the rate of 1000 lines per minute. The LEO Computers supplied to the G.P.O. will be able to operate two of these printers simultaneously and on quite different tasks if required.

Computing Center

*Institute of Technology
Karlsruhe, Germany*

In 1962 a Standard Elektrik ER 58 computer was installed at the Institute of Technology in Karlsruhe, Germany. The purchase was sponsored by the German Federal Research Association. The machine will be devoted mainly to the training of students and to the needs of all departments of the Institute.

The Karlsruhe installation consists of 6000 words of core memory, 12000 words of drum memory (access time 10 ms), 400 characters per second paper tape reader, and 50 characters per second paper tape punch. Additional equipment may be added in the future.

The ER 58 (see DCN, April 1960) is a serial, decimal, medium size, and medium speed computer. Fixed point addition time ranges from 0.3 to 0.9 milliseconds and floating point multiplication from 1.1 to 2.6 milliseconds. The structural center of the computer is an electronic cross bar switch, the rows of which are attached to subblocks (200 or 1000 words each) of the mainstore, whilst the columns are connected with the arithmetic unit, the control unit, auxiliary storage units, and the input-output devices. Simultaneous information flow from all sub-blocks of the mainstore to any one of the "Column-units" is possible.

A computer word has a length of 7 decimal digits, which constitute an instruction, a six-digit fixed-point number plus sign, or a string of three alphabetic characters plus special mark. Two successive locations can be processed together and are considered a floating point number or a fixed-point number of double length. Fixed-point arithmetic assumes the decimal point to the left of the most significant digit.

The instruction set comprises some 160 different instructions which give a very powerful and flexible tool for programming. The flexibility is enhanced by the possibility of using nine index registers and various one-bit and two-bit sense registers.

LEO III F

*Leo Computers Ltd.
London W2, England*

The Place of LEO III F in the LEO III Range

LEO III (see DCN, July 1962) is a general purpose computer, designed on the modular

principle which enables installations to be tailored to the requirements of the individual user. Additional storage or peripheral equipments can be added subsequently, should the work load expand.

The standard features of LEO III are buffered input and output and the running of several programs concurrently to make the best use of calculating power and peripheral speed. The name LEO IIIF designates a system with faster storage and arithmetic than LEO III. It is compatible in all ways with LEO III particularly in instruction code and peripheral equipment. As in LEO III it can perform arithmetical calculations in binary, decimal, sterling, or any other radix. Floating point arithmetic which is optional on LEO III is standard on LEO IIIF. It extends the already considerable range of LEO III to include the most demanding commercial, scientific, and industrial applications.

Special Facilities

The essential features of LEO IIIF are the ability to carry out more calculation work in a given time, and to handle data at a greater rate than LEO III. This calculating power can be needed when large files have to be processed at high speed and many calculations performed on each item.

Alternatively a LEO IIIF may be specified in order to obtain the maximum efficiency from a time-sharing installation where a heavy loading is expected, or to give a considerably enhanced performance on a mathematical calculation involving floating point working.

Compatibility

In general, jobs can be exchanged quite freely between LEO III and IIIF installations, provided they are equipped with similar peripheral equipment. No re-programming is required unless the user has added a custom-built microprogram (computer code action) in order to meet some special requirement.

Various features which are optional on LEO III are standard on LEO IIIF. These include floating point, merge and condense instructions, and lockouts and reservations to guard time-shared programs from interference with each other.

The 90K Magnetic Tape System (90,000 characters per second) which is available both on LEO III and IIIF systems can read tapes written by the less powerful systems and can be set to write at the lower density required by the 28K and 45K decks, thus giving two-way compatibility.

All standard peripheral devices with their standard assemblers can be connected to LEO

IIIF, which has eight input-output channels, to each of which several peripheral units can be connected via the same assemblers used on LEO III.

In consequence programs can be tested on LEO III and fully proved, before being run on LEO IIIF.

The LEO IIIF Storage

Two speeds of store are available with cycle times of 6 and 2 microseconds. Storage is supplied in multiples of 4096 words (one division). A Block of storage on LEO IIIF is a combination of one or more divisions of the same speed operating as a single unit. Blocks are expandable on site. A Block can be either one to four divisions of 6- μ sec storage (4096 to 16,384 words), or one to four divisions of 2- μ sec storage (4096 or 16,384 words).

LEO IIIF can have one or two blocks of storage. Both blocks of store are directly addressable and may be used for holding data and program. The programmer treats the two blocks as comprising a single homogeneous store in every respect but speed of operation.

Where there are two blocks they need not be of the same cycle time or size. By using a single division of 2-microsecond store in combination with a block of 6-microsecond store a substantial part of the arithmetic advantages of the faster access time may be gained for the installation as a whole (see Fig. 1).

This results from the arrangement whereby the two storage blocks operate independently and may be accessed concurrently. Thus, when one block is handling transfers of data, access to the other block is not delayed at all.

There need not, of course, be two blocks of storage. A LEO IIIF installation is functionally complete with a single division of store.

High Speed Channels—Provision is made for fitting up to three 90K magnetic tape channels on a LEO IIIF with 6-microsecond store (or four channels by special arrangement). Five 90K channels are allowed with 2-microsecond store.

Provision is made for the conversion of a number of channels to work at ultra high speed where more powerful peripheral equipments such as disc files may require this feature.

STORE ACCESS ARRANGEMENT

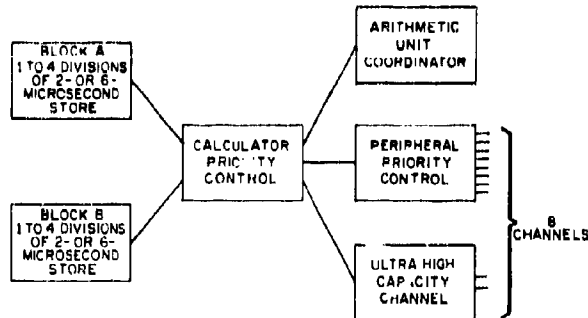

Figure 1.—The Calculator Priority Control allows the two Blocks of store to be used simultaneously and independently by the Arithmetic Unit, Peripheral Priority Control, and Ultra High Capacity Channel. Competing demands are dealt with on a priority basis.

Arithmetic Speed—The increased processing power of LEO IIF depends on the greatly enhanced speed of the coordinator and arithmetic unit. Computer code actions in LEO III are carried out by microprograms. This system now has added facilities which ease the work of implementing the microprograms and increase their speed.

The same LEO IIF arithmetic circuits are used for any store configuration. As the system is asynchronous, data and instructions can be processed as soon as they are available from store

Effective Arithmetic Speeds—Action times are given in Table I for LEO IIF-2 (IIF with 2- μ sec store) and LEO IIF-6. The effective speed with mixed store depends on where the program and data are held and varies between the speeds quoted for LEO IIF-2 and IIF-6.

Depending on store configuration and the application, LEO IIF will be 3 to 9 times as

fast as LEO III. In assessing calculating speed, allowance has always to be made for store engagement caused by input and output of data.

Size—The electronic circuits used in LEO IIF are more compact as well as faster than those in LEO III. The cabinets required are as follows; the figures in brackets are the comparable number of cabinets for LEO III, and show the reduction in size:

Arithmetic Unit)	
Coordinator)	
Peripheral Priority Control)	
Calculator Priority Control)	6 cabinets (9)
Enginers Control		1 cabinet (2)
Store (6 μ sec)		1 cabinet (1)
1 to 4 divisions		(oversize) to 4)
Store (2 μ sec)		1 cabinet per division

Table I. LEO IIF SPEEDS

Refinements in detailed design may affect certain of these timings. Averages are used in complex cases, and only the more significant actions are shown. For comparison the corresponding LEO III times are included. A line of 120 significant characters is assumed.

Actions	LEO IIF-2 (2-microsecond store) (μ sec)	LEO IIF-6 (6-microsecond store) (μ sec)	LEO III (μ sec)
Literal add/subtract	3-1/2	6	50
Add	4-1/2	12	34
Subtract	4-1/2	12	31
Select	4	12	27
Augment	7-1/2	18	50
Transfer	4-1/2	12	28
Copy	4-1/2	12	28
Multiply (e.g., 10x5 digits)	52	126	480
Multiply & add (10x5 digits)	75	82	1000
Multiply & subtract (10x5 digits)	75	82	1000
Divide (5 digit quotient)	83	90	750
Shift single length	5 + 1 per shift	7 + 1 per shift	29 + 6 per shift
Shift double length	5 + 1-1/2 per shift	7 + 1-1/2 per shift	29 + 6 per shift
Convert (5 digits)	42	65	300
Replace	7	14	72
Collate	5-1/2	12	52
Merge	20 per item plus 4-1/2 per word	67 per item plus 12 per word	175 per item plus 27 per word
Table look up	2 per item	6 per item	26 per item
Copy Registers	9	24	85
Change sequence	2	6	18
Conditional Sequence Change	4 or 3-1/2	6	20 to 66
Enter Sub Routine	4	12	33
Step & Test Modifier	10	24	54
Indirect Modify	6 + 4-1/2 per search	14 + 6 per search	23 + 34 per search
Input-output	14	18	80
Bulk copy	4-1/2 per word	12 per word	36 per word
Bulk clear	2-1/2 per word	6 per word	26 per word
Double length Arithmetic	8 or 9	18	80
Modification Times (average)	2	6	15
Unpack Fixed Field	250,000 characters per second	180,000 characters per second	33,000 characters per second
Unpack Variable Field	300,000 characters per second	190,000 characters per second	26,000 characters per second
Edit	160,000 characters per second	130,000 characters per second	20,000 characters per second
Condense	250,000 characters per second	160,000 characters per second	35,000 characters per second
Edit for G.P. Output	1.45 milliseconds per line	3.6 milliseconds per line	10.2 milliseconds per line

ZAM 2

*Instytut Maszyn Matematycznych
Warsaw, Poland*

The ZAM-2 Computer is a small-size electronic digital computer designed for solving numerical, statistical, and some data processing computation problems in science, industry, business, and commerce.

When designing this computer, high reliability as well as flexibility of applications and extremely simple programming (SAKP-autocode) were taken into account. Due to these advantages, the ZAM-2 Computer is able to save time and money solving the wide range of problems in different fields such as Structural Analysis, Linear Programming, Transportation Problems, Aircraft Construction, Ship Construction, Geodesic Calculations, Chemical Engineering, Electrical Engineering, Aero and Hydrodynamics, Nuclear Physics, Optics, and the like.

The ZAM-2 Computer is constructed of exchangeable plug-in-units. It contains about 850 electronic valves, 6000 germanium diodes, and 500 transistors. Only long-life electronic valves (10,000 hours guaranteed) are used.

Internal Structure

- Serial computer
- Synchronous operation
- Binary fixed-point arithmetic
- Single-address instruction modification by means of one 18-bit B-register

Programming

- Symbolic Address System (SAS)
- SAKO-autocode
- Library of subroutines (including linear programming algorithms and floating-subroutines)

Word Length

36 bits (so called "long word") or 18 bits ("short word"); each long word may comprise two instructions

Working Storage

- Magnetostrictive nickel delay lines 1024 short words
- Average access time: 0.36 milliseconds maximum
- Maximum access time: 0.72 milliseconds

Auxiliary Storage

- Magnetic drum
- 16,384 long words
- 1500 rpm
- Maximum of two drums may be connected

Clock Rate

405 kc

Basic Computer Cycle

90 μ sec

Fixed-Point Operations

- Addition: 90 μ sec
- Subtraction: 90 μ sec
- Multiplication: 3240 μ sec
- Division: 3240 μ sec

Average Operating Speed (Fixed-Point)

- Addition and subtraction: 100 op/sec
- Multiplication and division: 260 op/sec

Data Input

- High-speed tape reader, using five channels
- 300 characters per second maximum
- Maximum of two readers may be connected

Data Output

High-speed tape punch, using five channels
30 characters per second maximum
Maximum of two tape punches may be
connected

Supply

Three-phase, 380/220 v, 50 cps

Power Consumption

11 kva (approx.)

Outside Dimensions

Component	Length	Width	Height (mm)
Main Cabinet	510	2485	1845
Main Cabinet II	510	2485	1845
Magnetic Drum Storage	770	660	1230
Control Desk	1150	945	1340
Input Device Desk	1090	560	720
Output Device Desk	1090	560	720
Supply Cabinet	510	1730	1845

Space Requirements

Approx. 60 m²

Total Weight

Approx. 2 tons

Automatic Coding System

The ZAM-2 Automating Coding System was developed in order to lessen the effort and the time needed to prepare programs. The SAKO compiler acts as a translator between the user and the ZAM-2 Computer. The SAKO features are:

1. Similar to normal human language.
2. Easy in use.

3. Able to express any problem of numerical and statistical computation as well as some data processing problems.

4. Shortens the programming time about 10 times.

5. Eliminates programming errors.

6. Saves computer idle-work-time needed to develop programs written in the ZAM-2 Computer Code.

7. SAKO programs easily read.

8. Programs produced by the SAKO compiler are almost as efficient as those written by good programmers.

9. All subroutines of the ZAM-2 Program Library are adapted to operate in the SAKO system.

10. All elementary functions are included in SAKO.

Example of SAKO Application. Tabulating the function

$$y = x^2 + 6x \sin \sqrt[3]{e^{x^3} + \sin x} + \ln \sqrt{8x^3 + 1}$$

for x from 0 to 1 with the step 0.1. Results should be given with accuracy up to eight decimals after point.

The SAKO program appropriate to solve the problem is the following:

```
SET DECIMAL SCALE: 1
```

```
PARAMETER DECIMAL SCALE: 1
```

```
*1) Y=X*2+6xYxSIN(CBR(EXP(X*3+SIN(X))  
+LN(SQR(8xXx3+1))))
```

```
LINE
```

```
PRINT (1.1) : X
```

```
SPACE 10
```

```
PRINT (1.8) : Y
```

```
REPEAT FROM 1 : X = 0 (0.1)1.0
```

```
STOP 1
```

```
END
```

Some details of the arithmetic formula must be explained, namely

$x \cdot z$ denotes x^z ,

CBR denotes cubic root operation, and

SQR denotes square root operation.

The same program written in the ZAM-2 Computer Code consists of two or three hundred instructions. An experienced programmer would need at least 4 hours to prepare it.

After the SAKO program is recorded on five-level paper tape, the tape is read into the

ZAM-2 Computer. The SAKO compiler interprets it and PRODUCES A PROGRAM IN ZAM-2 COMPUTER CODE READY TO BE RUN IN ANY ZAM-2. The program may be taken from the Computer either in the ZAM-2 Symbolic Code or in the Internal Binary Form. Details are available in refs. 1 and 2.

¹ L. LUZASZEWICZ, "SAKO - An Automatic Coding System," Ann. Rev. in Autom. Progr. 2, 1961.

² A. MAZURKIEWICZ, "Arithmetic Formulas and the Use of Subroutines in SAKO," Ann. Rev. in Autom. Progr. 2, 1961.

Computing Center

*Shape Air Defence Technical Centre
The Hague, Netherlands*

The SHAPE Air Defense Technical Centre in The Hague installed a 32 K IBM 704 (with seven tapes) and a 4 K tape 1401 in February 1962. The Royal McBee LGP-30 has been retained. A Chronolog Digital Clock was attached to the 704 in August 1962 and the Floating Point Trap Feature in September.

Current areas of application of the system include:

1. Systems simulation, such as tracking studies, technical and operational studies of

ground environment systems, and air defense weapons coordination;

2. Information requirement and decision models for study of electronic data processing in integrated command and control;

3. Reduction of radar flight test data.

Available software includes FORTRAN, IPL 5, and NELLIAC.

DT 12 Data Transmission System

*Standard Elektrik Lorenz A.G.
Stuttgart, Germany*

Data Transmission over Long Distances with DT 12—Smooth operation of present-day industry and public administration is to a large extent dependent on the speeds at which urgent information can be transmitted and processed. This information may consist of data, for example the accounting records collected during a business day by distant branch offices of an enterprise, which have to be transmitted to the central office for processing as soon as possible. These data are in most cases obtained by machine methods and are evaluated by computers.

The problem faced was to develop a transmission system providing high-speed, error-free,

and economical transmission of such data over existing communication lines, e.g., telephone circuits. The data transmission system DT 12 solves this problem because it features:

High Speed Operation—The transmission speed is 600 or 1200 bauds, in compliance with recommendations of the German Post Office and CCITT; therewith it meets requirements for international communications. For comparison: Telex messages are transmitted at a speed of 50 to 75 bauds.

Error Free Operation—Transmission errors due to noisy lines are automatically detected, and automatically corrected by reiterative

transmission. At worst conditions, one undetected error only will be encountered in 14 6-hour days of operation. With telephone lines operating under normal noise conditions, this period will extend to 5 months. Another advantage is that the receiving end obtains punched tape copies without correction marks (clean tape).

Independence of the Code Used—Transmission is on an alphanumeric basis; differing systems (input and output equipment) may be combined.

Universal Application—Any transmission path suitable for speech transmission may be used: carrier channels, power lines, or radio channels. Similar to the telephone toll dialling service, selection by card diallers is possible. Operation is extremely simple.

Economical Operation—The DT 12 permits utilization not only of existing communication networks but also of reduced tariffs, e.g., the night tariff for a large volume of data. Automatic facilities permit unattended operation of the receiver or the transmitter.

Planning With a View to Future Requirements—Input and output speeds of up to 10,000 bauds are admissible. DT 12 transmits data with any desired coding over telephone lines at high speed, error free, and rationally.

Industry—Branch plants, for example, may use the DT 12 to transmit wage accounting records (per piece pay, personnel action notices) to the central payroll office shortly before wage accounting date. The information is processed there (by electronic or electromechanical facilities, or manually) and the completed pay roll lists are transmitted by means of DT 12 to the branch plants in extremely short times.

Other applications are production control, handling of orders, central stock-keeping and material disposition, and error-free digital transmission of metering values.

Banks and Insurance Companies—The DT 12 is used to keep central accounting and customer files up-to-date, to supplement statistical records, and to provide within seconds information required.

Trade and Storing—Chain stores, branch offices, and customers convey their orders to a centralized stock room with the aid of the DT 12. The information, or information carriers, serve not only as ordering records

but also for purposes of automatic stock accounting, bookkeeping, and invoicing. The advantages are obvious. Rational and quick processing of orders and minimum volume of stock-on-hand.

Traffic—In traffic, e.g., aviation, the DT 12 may be used for the recording of all flight reservations at one centralized office. Booking data are immediately passed by the individual agencies to a central booking computer which is able to report within seconds whether or not the seats requested are available. This permits immediate customer service, eliminates the danger of accepting too many bookings, and renders provision of reserve seats unnecessary.

Other applications are weight and balance dispositions and centralized stock-keeping.

Administration—Tax offices, statistical bureaus, social security institutions, and the like, utilize the DT 12 to transmit information to their headquarters for processing and evaluation.

Universities and Institutes—The DT 12 is used to exchange information and data as well as to contact data processing and documentation centers. Meteorological centers employ the DT 12 for constant communication with the weather stations.

Input—Every information source that can be stopped and started exactly at any point, may be connected to the transmitter when suitably adapted. Punched tape equipment and ferrite core memories may be adapted to the transmitter at a minimum of expenditure.

Transmitter—Regardless of the code used, the data to be transmitted are divided into block memories in the form of blocks of a certain length, and then transmitted block by block. A disturbed block is repeated until its error-free reception. In the case of undisturbed transmission, block follows block. The transmission path also serves for speech communication between terminals.

Receiver—The blocks received are written, synchronously with the transmitter, into block memories and checked for errors by electronic facilities. A disturbed block is automatically repeated. Thus only error-free blocks are passed to the output equipment via the adapting unit. The transmission path also serves for speech communication between terminals.

Output—Every output unit that can be stopped and started exactly at any point, may be connected to the receiver, when suitably adapted. Punched tape equipment and ferrite core memories may be adapted to the receiver at a minimum of expenditure. A combination of different input and output units is possible, e.g., a tape reader may be used at the transmit end and a core memory at the receive end.

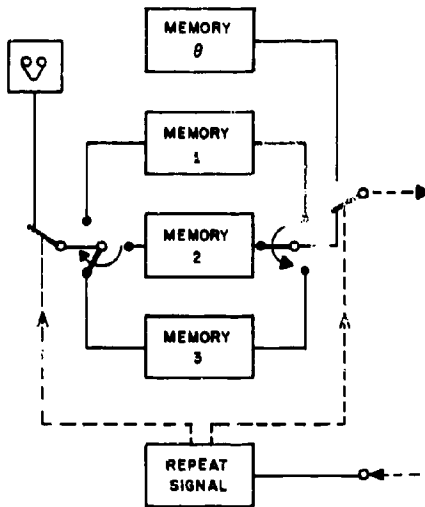

Figure 1.—Transmission Logic.

At the transmit end the data to be transmitted are passed, via the adapting unit, one of the three block memories (1, 2, or 3) which are cyclically connected to the information source.

As shown in figure 1, the input device works into memory 3; memory 2 is transmitting to the receiver while memory 1 (which had transmitted a block before memory 2) holds the information until a confirmation signal acknowledges correct reception of the data. Upon arrival of this signal, memory 1 is erased and made available for accepting the next block. The error correction unit sends a start signal to the information source which thereupon commences reading and supplies to the central control the clock pulse for reading-in. A clock generator in the modulation equipment produces the clock pulse for the transmission of the block.

Each of the block memories has a capacity of 63 bits, comprising 42 information bits and 21 check bits. During read-in, the incoming information bits are counted and the information source is stopped upon arrival of the 42d bit (information quantity of the block memory). If

necessary, the stop may be initiated at an earlier time with consideration of delays encountered with mechanical input equipment.

Simultaneously with the read-in process, a counting circuit extracts the check bits, so that the block may be transmitted without loss of time. In case of undisturbed transmission, block follows block.

In case an error occurs in the transmission of a block, a repeat signal instead of a confirmation signal is sent to the transmitter over the return channel. This signal effects transmission of a blocklength signal sequence (0 signal) instead of the next block. The disturbed block is then repeated, if required several times, before resuming normal transmission cycle.

The transmission system DT 12 is flexible. The terminals are made up of plug-in units and subdivided into the adapting unit, error correction unit, and modulation unit.

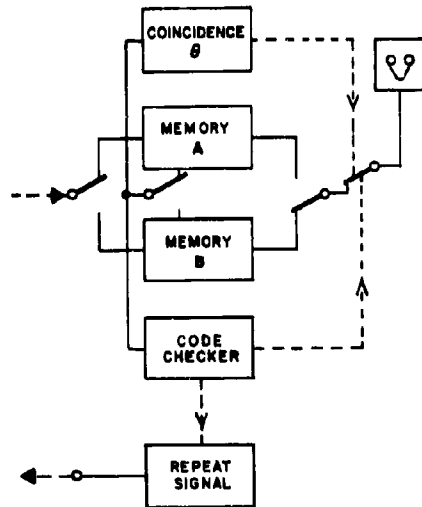

Figure 2.—Receiver Logic.

At the receive end the blocks transmitted (42 information and 21 check bits) are written cyclically into the block memories A and B. Figure 2 shows a block just being entered into memory A while the contents of memory B (after a code check had proved correctness) passed on, via the adapting unit, to the output equipment. Analogously to the operation at the transmit end, a counting circuit again derives 21 check bits and compares them with the check bits transmitted. In case of coincidence, the

error correction unit delivers a start signal to the information output, the information output equipment commences receiving and supplies the clock pulse for the read-out of the error-free block.

During read-out, the information bits are counted and the output equipment is stopped at the 42d bit. With consideration of the delays encountered with mechanical equipment, the stop may be initiated at an earlier time. In case the code check revealed an error, the output equipment does not receive a start signal. The disturbed information block as well as the following block are erased, instead. The receiver

transmits a repeat signal instead of the confirmation signal over the return channel. The 0 block, the transmission of which is initiated thereby, announces a repetition of the disturbed block. Only upon error-free reception of this block is the normal reception cycle re-established. Synchronism of transmission is achieved again even after disturbances of any length.

The transmission system DT 12 does not require any specific signal code. Counting of bits during input and output permits reading of various codes into the block memories. Positions unused can be filled in with zeros.

Miscellaneous

Tactical Moving Map Display

*Computing Devices of Canada Ltd.
Ottawa 1, Canada*

The inadequacy of the counter-type display for the indication of present position to the pilots of low-level, high-speed, tactical aircraft has long been recognized. In order for a pilot to be effective on a low-level mission, he must be continuously aware of the relation between his current flight path and the surrounding and approaching terrain. To meet this need the Tactical Moving Map Display, recently introduced by Computing Devices, provides for the pilot a display of a brightly lit topographic map, the centre of which will at all times represent his position and with a radial vector marking his track. In addition, to overcome cockpit space limitations, the versatility of the instrument can be increased by including optional features which display track error, desired course, and range to destination.

These features can be added without increasing the size of the basic instrument. The design of the instrument has been strongly influenced by considerations of the operational stresses imposed on the tactical pilot. The result is a semi-automatic navigation instrument which requires a minimum of manipulative actions on the part of the pilot. Any one of a wide range of sensors and navigation computers including Computing Devices Position & Homing Indicator (PHI) or Global Lightweight Airborne Navigation computer Equipment (GLANCE) can furnish the necessary inputs.

Present Position Indication

The display consists of a 5-inch diameter screen upon which a correctly oriented colour image of the map is projected. Present position is indicated by a small fixed circle in the middle of the screen. As the aircraft moves over the terrain the map image moves correspondingly along the track line and past the present position circle.

Steering Indications

The unit also presents an integrated display of other information required by the pilot

for effective aircraft navigation. Track, course, and range-to-destination are presented on counters. Track error is indicated by a triangular shaped pointer which moves around the circumference of the map display area. To make good a track to a destination requires only that the aircraft be steered so that the track error indicator and the aircraft track line are made coincident. The pilot is continuously free to deviate from his flight plan anywhere within the map coverage area of 1800 x 1800 nautical miles.

Map Display

The maps used for the display are standard 1:500,000 air navigation charts reproduced on a single strip of 35-mm colour film. This strip provides continuous coverage of an area 1800 x 1800 nautical miles. A map drive unit within the instrument orients the film strip and moves it automatically and continuously in accordance with the path of the aircraft. The pilot is not required to make any adjustments to the display other than correcting the position when necessary. The map image is presented in full colour and is clearly visible over a wide range of ambient light conditions. The high image resolution of the system permits easy recognition of symbols and lettering as small as 1/32 inch. Map filmstrips of operational areas can be prepared by Computing Devices of Canada or by any other suitably equipped facility.

Look-Ahead, Destination Insertion and Position Up-Dating Facilities

In the AHEAD mode, the pilot may select any direction and manually slew the map to display any area. In this mode the range and course counters will display the range and bearing of the ground feature located in the present position indicator relative to the aircraft's actual position. Manually controlled map movement is achieved by the use of the course and range control knobs on the unit face. The map display, at command, automatically returns to

present position after the look-ahead operation. When the mode switch is in the LEG position the pilot may insert the range and course of his next destination. When the display is returned to the TRACK mode the range counter will count down the distance to go and the course counter will show the bearing to fly. An alternate method of destination insertion is by means of the PHI-type station selector. If an "on-top" position fix indicates the displayed position to be incorrect, it is possible to up-date the display by setting the mode switch to the FIX position and adjusting the range and course controls. When the display is not in the TRACK mode a limited memory storage facility ensures that no position information is lost.

Display Controls

On the pilot's instrument, map orientation is slaved to the aircraft track. It is possible however, to orient the map to North at 12 o'clock by depressing the spring-loaded course knob. Heading orientation can be provided in lieu of track orientation if desired. In both operating modes the current track of the aircraft is shown by a radial line from the centre of the display. A map scale control enables two map scale factors, 1:500,000 and 1:1,000,000 to be selected. The 1:500,000 scale is provided to enable the pilot to distinguish detail of topographic features for low altitude work and provides a viewing radius of 17 nautical miles from present position. The 1:1,000,000 scale provides a viewing radius of 34 nautical miles. The AHEAD feature extends this viewing radius to any range the pilot may desire, within the limits of the equipment. Additional controls on the instrument enable the pilot to set the brightness level of the map image. An optional automatic brightness level of the map image. An optional automatic brightness feature can be provided to maintain the brightness level, relative to ambient light, at any desired setting.

Alternate Display Capability

Supplementary flight information other than topographic map detail can be incorporated on the film strip for display at will. Typical of these alternate displays are target or airport approach data, emergency operating procedures, and air traffic control procedures.

Input Information Sources

The map display unit is operated in conjunction with a coupler unit which transforms information from different types of sensors and navigation computers into a form suitable for the map display unit. An optional feature for the computation and display of range and bearing to destination can be furnished if the navigation computer does not provide these as outputs.

Specifications

Operational Limits:

Range Counter	1000 nautical miles
Course Counter	0-360°
Track Counter	0-360°
Area of Coverage	1800 X 1800 nautical miles (approx)
Maximum Speed	2000 knots

Power Requirements:

114 v, 400 cps, 55 w
26 v, 400 cps, 35 w
28 v dc, 185 w

Weight:

Display Unit	10 lb (approx)
Computer Coupler	12 lb (approx)

Dimensions:

Display Unit	6 x 6 x 11-1/4 inches
Computer Coupler	3-9/16 x 19 x 7-5/8 inches (3/8 ATR long)

Accuracy Limits:

1 mile + 1/2% distance flown

Environmental Performance:

Display Unit	MIL-E-5400E Class 1
Computer Coupler	MIL-E-5400E Class 2

Projects FIST and SAFARI

National Bureau of Standards
Washington, D. C. 20234

Project FIST

Engineers at the National Bureau of Standards (U.S. Department of Commerce) have devised FIST (Fault Isolation by Semi-Automatic Techniques), a troubleshooting system that approaches the ultimate in simplicity. Intended for use on modularized electronic equipment, this system is being developed for the Navy Bureau of Ships by Gustave Shapiro, George Rogers, and Owen Laug of the NBS staff. It was described to key personnel concerned with equipment maintainability in government and industry at a one-day seminar held at NBS September 12, 1963. Now being applied to a naval radar equipment, the system promises, when more widely adopted, to have far-reaching consequences in training and procedures used for maintaining electronic equipment.

The amount and complexity of electronic equipment used in the military services has multiplied greatly in the past two decades,

creating a need for many more skilled technicians. This, in turn, has led to continuing recruitment and training problems in the services. The resulting high cost of maintenance has increased the importance of reliability and maintainability as criteria in planning and accepting new electronic equipment.

Now being applied experimentally to a first equipment, the new trouble-shooting system is expected eventually to have an impact on the maintenance of military and other high-reliability electronic equipment comparable to that resulting from modularization. The system, figure 1, consists of a small, hand-carried general purpose test instrument together with the special circuits and receptacles built in as part of the prime equipment being tested. The test instrument has a red light, a green light, a test plug on a cord, and a self-test receptacle; it includes four voltage comparators and logic circuitry. The operator can check tester operation at any time by plugging it into its self-test receptacle.

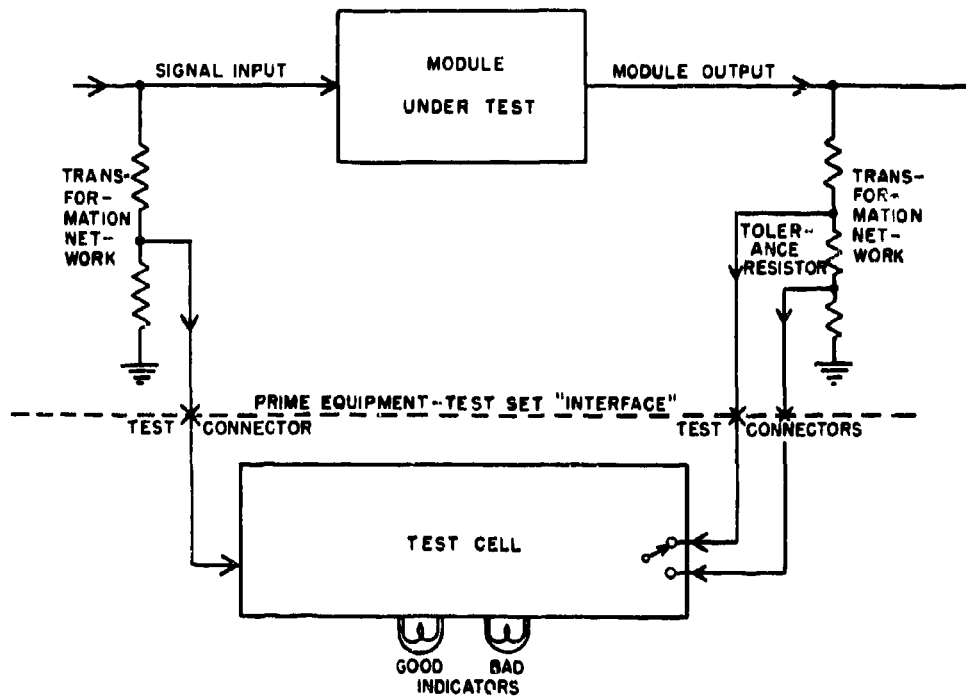

Figure 1.

In use, the test set, which occupies only a fifth of a cubic foot, gives a green (good) or a red (bad) indication when plugged into each test receptacle at which a test is possible. The module is within tolerance if a good indication is obtained. If neither indicator lights—the no-test response—this indicates that all needed inputs are not present at the module. The operator can test the modules in any order with a uniform simple procedure for all types of tests. He can save time, however, by first plugging into each group test receptacle to localize the area of failure, and then into the constituent module receptacles to find the defective module.

Circuits needed by the system to adapt module operational parameters for good-bad indication by the test instrument are in the prime equipment. They are being designed with subminiature components on printed circuit boards, so they can be mounted on the backs of the module test receptacles. All of these transformation networks are passive, permitting the measurement of properties such as ac and dc voltages, frequency, amplification, voltage waveforms, impedance, frequency response, and a variety of other electronic and physical measurements. Each transformation network operates to permit each desired operational and circuit parameter to be sensed as small voltages.

The test set operates by comparing two voltages for each test, such as the input to an amplifier module and its output. The design of the transformation network is such that it converts the amplifier input and output signals into voltages of comparable magnitude provided that the amplification is within design tolerances. The test set comparator determines whether or not these voltages have comparable magnitudes.

The output signal is actually obtained alternately at opposite ends of one of the resistors in the attenuation network, the components of which have such values that the normal attenuated voltage is obtained at the high end of the tolerance resistor for a module of the lowest acceptable gain and at the low end for the highest-gain module acceptable. Any module of this type having a gain between the acceptable limits must produce an output signal that is greater than the ideal level when sampled at one end of the tolerance resistor and less than the ideal at the other end.

The comparator input is switched alternately between the ends of the tolerance resistor, so that its output changes polarity in testing a module characteristic within the specified limits. This makes for simplification of the

circuitry and the indication. The comparator drives a zero-crossing detector circuit which operates the green (good) indicator light if the comparator output changes polarity and crosses zero. Failure of the comparator output to reverse polarity (indicating a module characteristic exceeding either limit) causes the detector to energize the red (bad) indicator.

A simple one cell test set would consist of two input amplifiers, identical except for one having a switch selecting its input from either end of the tolerance resistor; two peak-to-peak detectors to rectify the signals; a differential dc amplifier to compare them; a zero-crossing detector; and logic circuits. Four such cells in each test set permit the simultaneous measurement of interacting module parameters. The test set operator needs no skill or training to identify and replace the failed module; he need know no more about electronics or the equipment being tested than the maintenance man who replaced the electric light bulbs. The technicians are called in only if the "bulb charger" is unable to find the malfunction, as in the case of faults in cabling or connector wiring.

Project SAFARI

FIST design techniques not only carry on the maintenance revolution already started by modularization, but have already sired a project promising an even more radical change in maintenance. This is Project SAFARI (Semi-Automatic Failure Anticipation Recording Instrumentation), a system of measuring and recording equipment performance. SAFARI consists of a tester, much like the FIST tester except that it presents performance figures in a graphical form using a device for recording and viewing module performance as a function of time.

Project SAFARI uses equipment performance measurements obtained from a test device similar to that of FIST, but which in addition graphically plots successive measurements for comparison with an established rejection level. The rate at which the performance approaches this level can be easily monitored and the module replaced before the rejection level is reached. This procedure could add a new order of reliability to electronic equipment that is used where reliability is the greatest consideration.

The greatest impact of the FIST troubleshooting system is expected to be in alleviating

the shortage of capable electronic technicians, by enabling unskilled personnel to do many of the required tasks. Secondary effects will be a higher level of dependable operation due to better maintenance, reduced numbers of technicians to be trained and the accompanying possibility of creating a small elite corps of technicians, trained in greater depth. While not all

equipment failures can be troubleshot by means of FIOT, repaired by module replacement, or anticipated by SAFARI, the number of failures that respond to these techniques is expected to be sufficient to greatly reduce the burden of troubleshooting and repair now performed by technicians.

Foreign-Currency Scientific Program

*National Bureau of Standards
Washington, D. C. 20234*

Scientific groups in underdeveloped countries working under NBS contracts have shown that they can extend the research capabilities of the National Bureau of Standards (U.S. Department of Commerce) and American industrial and scientific interests in addition to raising technological levels abroad.

This fact is one of the first conclusions to emerge from the Bureau's new Foreign Currency Program. In the year and one-half since the program was instituted, NBS has awarded 27 grants and contracts to support technical projects in India, Israel, and Pakistan. According to Dr. Franz L. Alt, coordinator of the program, each grant or contract promises to contribute to one or more of the Bureau's basic needs, such as more accurate standards of measurement; compilation and measurement of critical data or standard reference data on physical constants and properties of materials; or improved methods for high precision measurement.

Most of the projects were developed by scientists in the three foreign countries with the cooperation of their Bureau counterparts. Each proposal was accepted on the basis of its contribution to the Bureau's mission, its general scientific merit, and its cost in relation to the funds presently available.

Salaries for scientists and assistants, equipment, travel, and other costs of research can be provided by the grants. Funds for the

program—a total of \$1,500,000 thus far—were appropriated under a special section of the Agricultural Trade Development and Assistance Act of 1954. It is expected that grants and contracts will continue to be awarded as relevant proposals are received.

The opportunity to participate in this program arises from the Agriculture Trade and Development Act of 1954, which enabled many foreign countries to buy surplus U.S. agricultural products and pay for them in local currency rather than in dollars.

As these foreign currencies accumulate, the United States can use them for a variety of purposes, but only in the country in which they originated. When these funds exceed the normal needs of the U.S. Government, as has happened in a few countries, the Congress may authorize the use of some of the surplus for scientific purposes. This is why NBS has been limited to three countries, although the program may, in the future, be extended to a few others.

This program complements the work normally conducted by the Bureau although most of the projects would not have top priority at this time. All of the studies, however, represent work that NBS should be doing and would ultimately have to do and pay for in dollars if foreign currencies were not available. Since this research can be conducted now, the Bureau gets the advantage of top level scientific research which meets timely and definite needs.

Real Printing

*National Bureau of Standards
Washington, D. C. 20234*

With the cooperation of the Mergenthaler Linotype Company, the National Bureau of Standards has prepared a volume, entitled

"Experimental Transition Probabilities for Spectral Lines of Seventy Elements," using an IBM 7090 computer and the Mergenthaler

Linofilm System of photographic type setting equipment.

The tables in this book were composed by a photographic composition machine controlled by the output of the digital computer. The computer generated a magnetic tape containing all of the printed material, including column headings, decimal tabular material and page numbers. In addition the tape contained the necessary printing instructions for font selection and page layout. This output magnetic tape then became the input to the photo-composition machine which produced auto-positive films. These in turn

were used to produce direct offset printing plates from which the book was prepared.

In the future the output magnetic tape will be run through a converter which will produce 15-channel paper tape which in turn will become the input to the commercially available photo composition machine.

The fact that it is possible to use many different fonts, to adjust point size, to use superscripts and subscripts, and so on, in fact to do anything that is done by the present hot lead techniques, suggests that this technique will have wide application.